



**KEY FEATURES**

- 8 models ranging from 15 to 750 hp
- Stainless steel
- No special foundation required
- Adjustable air intake port
- Heavy duty construction
- Rotor assembly dynamically balanced for smooth operation
- Large doors provide easy access for replacement or adjustment of internal parts
- Grinding plates and liners can be furnished with hardened material for extended life when grinding abrasive materials

**KEY BENEFITS**

- Attrition milling through particle to particle collisions enhances ability to grind less friable or abrasive materials that are difficult for a fine grinder or classifier mill
- Combines several operations such as de-agglomerating and surface coating into one system, eliminating the need for multiple material handling systems
- Ability to spin flash dry and grind in one step save on capital investment and increases process efficiency
- Ability to grind slurries and products with higher fat/ oil content

**GENERAL DIMENSIONS \***

Model	HP Mill	Nominal Airflow CFM m <sup>3</sup> /hr	A (in mm)	B (in mm)	C (in mm)	D (in mm)	E (in mm)	F (in mm)	G (in mm)
RM-1300	30	500	53	41	57	65	30	28	30
		850	1346	1041	1448	1651	762	711	762
RM-1500	30	500	45	34	47	46.5	20.5	23.5	24
		850	1143	864	1194	1181	521	597	610

\* Do not use for engineering purposes. Please request a certified drawing for all layout or construction purposes.

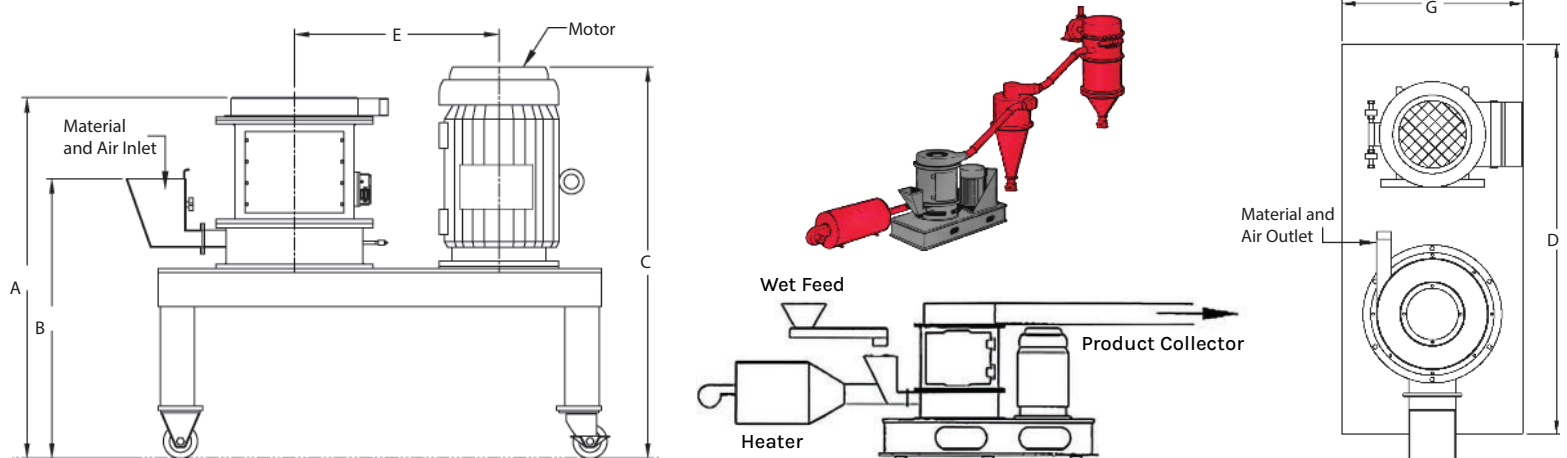

# GENERAL DIMENSIONS \*

Model	HP Mill	Nominal Airflow CFM m <sup>3</sup> /hr	A (in mm)	B (in mm)	C (in mm)	D (in mm)	E (in mm)	F (in mm)	G (in mm)
RM-3000	50-200	2300	57.5	23	50.5	85.5	32.5	14.5	40
		3908	1461	584	1283	2172	826	368	1016
RM-4500	100-300	6500	42.5	40.5	69.5	116	47	9.5	67
		11044	1080	1029	1765	2946	1194	241	1702
RM-4800	100-300	6500	100.5	39	77.5	126	55.5	23.5	68
		11044	2553	991	1969	3200	1410	597	1727
RM-6000	150-350	11000	105	39	78	144	36	23.5	79
		18689	2667	991	1982	3658	914	597	2007
RM-7000	150-500	13000	102.5	53.5	77	154	66	23.5	89
		22087	2604	1359	1956	3912	1676	597	2261
RM-8000	500-700	20000	125	43	105.5	170	78.5	26	95
		33980	3175	1092	2678	4318	1994	660	2413

\* Do not use for engineering purposes. Please request a certified drawing for all layout or construction purposes.

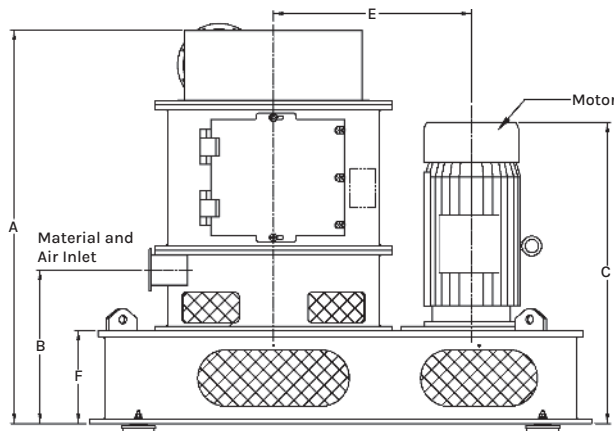
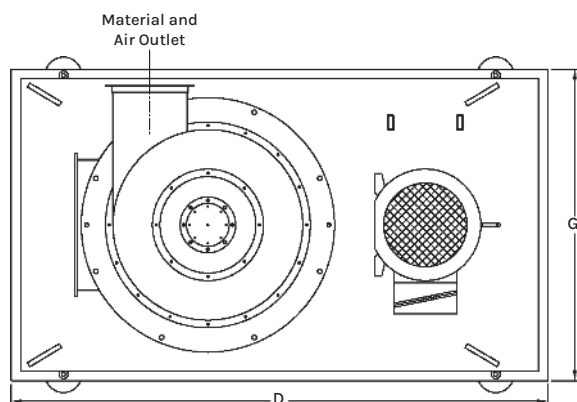

## THEORY OF OPERATION

- Particles are pulverized to small sizes by inter-particle collisions induced by very high turbulence within the mill. The pulverizing action is generated by an internal rotor that spins at high speeds. Heavy-duty bearings provide stability during the pulverization process. These bearings are housed outside the grinding chamber to prevent product contamination.
- The rotor consists of two sections:
  - A Lower Section that functions as a material distribution fan
  - An Upper Section where the material is finely ground
- Grinding occurs at several stages within the upper section. A series of grinding plates accelerate the air and particles against the grooved lining of the Rotormill interior. Miniature pockets of high-velocity, turbulent air cause particle-to-particle collisions and pulverizes the material. Internal heat is absorbed by the continuous flow of air.
- Varying airflows, adjustable grinding plates, and specialty plate types allow for the processing of a wide variety of materials and sizes.
- Adding heat to the feed inlet allows for the material to flash dry during the milling process.

