



SCAN ME



905-607-3240
sales@ratetechnology.com
www.ratetechnologysystems.com



2 Sammons Court
Bolingbrook, IL 60440



(844) 942-2966



www.praterindustries.com



www.praterindustries.com

ABOUT PRATER

Prater Industries is a dynamic manufacturing company with a century-old tradition of providing excellence in industrial equipment and solutions with a future-focused mindset. With a long history of being at the forefront of manufacturing innovations, we continue to anticipate changes in regulations, technology, and customer demands, and then work hard to meet these challenges head-on. We are an energetic team, always looking for new ways to transform and be at the leading edge of particle separation, size-reduction, and process solution challenges.

Founded in 1925 by Ralph Prater, Prater Industries (then known as the Prater Pulverizing Company) began by designing and manufacturing hammermills for the growing feed industry. The company continued as an intrepid, family-run business for decades.

As new opportunities presented themselves, Prater's entrepreneurial spirit kicked in to produce a wide variety of novel product and application solutions, including lump/cake/flake breakers, hammermills, fine grinders, air classifying mills, deck screeners, rotary sifters, and air classifiers as well as a full line of rotary airlock valves.

Today, Prater Industries operates under the IMI Holding Corporation umbrella and continues to thrive by providing ingenious and creative solutions for a wide variety of industrial applications.



WHY DO WE EXIST ?

Prater brings people together to provide process solutions that feed, nurture, and house the world.



WHAT DO WE DO ?

We develop and provide innovative, tailored material size reduction, separations and process solutions.



HOW DO WE BEHAVE ?

- Integrity
- Delivering Results
- Customer Focus
- Resilience
- Innovation
- Teamwork & Collaboration
- Continuous Improvement
- Adapting to Change



HOW WILL WE SUCCEED ?

We will create economic value centered on product and service knowledge.

We rely on delivering a higher level of application knowledge to consistently beat our competition



SPARE PARTS & SERVICE

Consult with our experienced, professional Customer Service Representatives with any and all equipment support inquiries.



BROWSE OUR AIRLOCKS

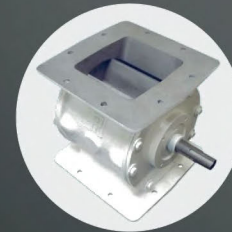

Dust Collector Series



Heavy Duty (PAV Series)

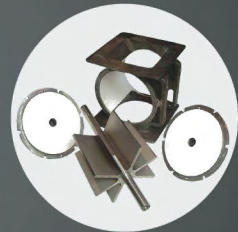

Abrasion Resistant



Quick Take Apart (QTA Series)



QTA Series (On Rails)



Blow-Thru (PBT Series)

Rotary Airlock Valve Feeders manufactured by Prater are designed to provide improved performance to bulk material processing and production operations. In dry material metering applications, our valves ensure accurate material loading and unloading while also functioning as highly efficient rotary airlocks; minimizing pressure loss throughout the system.



Our customers rely on Prater Rotary Airlock Valve Feeders to perform various functions such as:

- Feed process materials into pneumatic conveying applications
- Regulate the flow of material from one chamber to another
- Metering of process materials in loading and unloading applications
- Minimize air loss while transferring material between vessels with differing pressures
- Operating up to 500°F for standard models and up to 1000°F for custom models
- Compliance with NFPA-69 standards as well as being third-party tested

Prater's Rotary Airlock Valves can be configured and customized for most application requirements, especially for materials that may be highly abrasive. We understand the need for feeding more material at lower speeds, which is why our rotary airlock feeders are manufactured with larger pockets. In turn, this design minimizes air leakage, provides the benefit of longer life, and ensures a higher return on investment. Our rotary valves perform well wherever dry free-flowing powders, granules, crystals, or pellets are being processed.

APPLICATION SPECIFIC MODELS

- **Heavy Duty Models:** Prater heavy-duty PAV series is the workhorse of the industry with numerous options for rotor designs, seals, and accessories
- **Quick Cleaning Models:** Prater QTA and BAV series are designed with direct drive and 2-piece rotors for easy, tool-free maintenance. Pre-gapped rotors eliminate the need for post-installation adjustment. The BAV series is equipped with a linear rail system for easy rotor setup and removals

- **Abrasion Resistant Models:** This is the most durable model available anywhere. Hardened rotor tips, premium seals and specialty (tungsten, chrome, or ceramic) wear coatings are standard. Manufactured especially for use with abrasive materials
- **Blow-Through Models:** Prater's blow-through series is designed and manufactured specifically for applications that require discharging into a pneumatic conveying line. These Airlocks are ideal for free-flowing materials that require some assistance in clearing the rotor vane pockets. The design of the Prater Blow-Thru Airlock makes installation possible in low headroom applications and retrofits of existing rotary valves

KEY FEATURES AND BENEFITS

Housings

- Precision machined, heavy-duty cast iron or stainless steel construction providing long life and durability with minimal air loss at operating temperature ranges. Designed for up to 15 psi differential pressure
- Our universal flange allows for the flange hole mounting pattern to match the customer needs
- CFR (Cubic Feet per Revolution): Industry leading CFR allowing up to 50% more volume per revolution. This enables the rotor to run at lower speeds than other manufacturers, increasing efficiency and equipment life. Alternatively it may allow for a smaller Prater airlock
- Large feed throat design for maximum fill of rotor pockets
- Compact size and head height allows for easy installation or replacement of most competitors airlocks
- Standard transitions required to replace competitor airlocks available

Drives

- Consistent 5.1 torque ensured by inverter-duty motors with integrated gearboxes and heavy-duty chain drives (Direct-drive available)
- Prater standard drives are a premium design that offers more HP for what others consider a heavy duty upgrade
- Quadralip seals provide maximum protection against contaminants
 - Uni-case housing ensures maximum oil, seal, and bearing lifespans while running with less noise

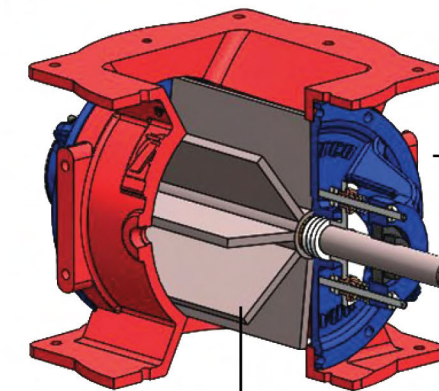

End plates

- Easy maintenance ensured with quick-change packings
- Designed with more space between the bearing and seal plate that allows for packing change with the valve fully assembled

Bearings

- Easily replaceable, outboard-mounted, maintenance-free lubricated bearings
- Bearings sealed for life to provide no-maintenance-required airlock lifecycle

Rotors

- Precision machined fabrication for industry-leading rotor-to-housing design clearance minimizes air leakage
- Eight-blade design for smooth operation and maximum seal ensuring minimal deflection as compared to 6 blade designs
- Custom-designed application solutions are available

Packing Glands

- Self-adjusting design ensures consistent load on packing to reduce leakage and help extend shaft seal life. Designed for simple maintenance

Heavy Duty Series Rotary Airlock Valve



FEATURES

- Constructed of high strength cast iron or stainless steel body & end plates
- 8 blade, open-end rotor with welded pocket bottoms
- Self-adjusting, maintenance-free packing gland assemblies
- Outboard mounted, maintenance-free bearings
- Universal flanges custom-drilled at no extra charge
- Complimentary temperature compensation
- End plates pre-drilled & tapped for optional shaft air purge
- Quick and easy end plate removal using included jack bolt holes
- Operating temperature up to 500° F with standard components
- Keyed shaft extension for most drive assemblies
- Premium, inverter duty, helical gear motor
- Standard models in stock

OPTIONS

- Air purged seals
- Food grade Teflon seals
- Food grade white epoxy paint
- 304 or 316 stainless steel body & rotor
- Hastelloy body and rotor
- Shear pins / Zero speed switch
- High temp bearings & seals for operation to 1100° F
- Wear & corrosion resistant coatings
- Inlet baffle / Inlet v-plow for shear protection
- Discharge adapter / Finger guards
- Bolt on or flexible tips
- Vented pockets / Vented housing
- Die cut flange gaskets
- Manual hand crank or pneumatic maintenance gates available
- Drive: TEFC, or TEXP / Various voltages available

THE ONLY AIRLOCK
IN NORTH AMERICA TO BE
TESTED & CERTIFIED
TO COMPLY WITH NFPA-69

- NFPA-69
- MSHA
- V-Plow
- 10-Bar
- PSR11
- CSA

Square (PAV Series)

Airlock Capacity Table

8 VANE ROTORS

Size	CF/REV	RPM																							
		3	4	5	6	7	8	9	10	11	12	13	14	15	16	17	18	19	20	21	22	23	24	25	26
6	0.12 **	22	29	36	43	50*	58	65	72	79	86	94	101	108*	115	122	130	137	144	151	158*	166	173	180	187
8	0.24 **	43	58	72	86	101*	115	130	144	158	173	187	202	216*	230	245	259	274	288	302	317*	331	346	360	374
10	0.42 **	76	101	126	151	176*	202	227	252	277	302	328	353	378*	403	428	454	479	504	529	554*	580	605	630	655
12	0.76 **	137	182	228	274	319*	365	410	456	502	547	593	638	684*	730	775	821	866	912	958	1003*	1049	1094	1140	1186
14	1.18 **	212	283	354	425	496*	566	637	708	779	850	920	991	1062*	1133	1204	1274	1345	1416	1487	1558*	1628	1699	1770	1841
16	1.84 **	331	442	552	662	773*	883	994	1104	1214	1325	1435	1546	1656*	1766	1877	1987	2098	2208	2318	2429*	2539	2650	2760	2870
18	2.2 **	396	528	660	792	924	1055	1188	1320	1452	1584	1716	1848	1980	2112	2244	2376	2508	2640	2772	2904	3036	3168	3300	3432
22	3.45 **	622	829	1037	1244	1452	1659	1866	2074	2281	2488	2696	2903	3110	3318	3525	3732	3940	4147	4355	4562	4769	4977	5184	5391

** Calculated @ 80% Fill Efficiency

* Available in Direct Drive

To size an airlock, use this formula:

$$\text{Rate} \div \text{Density} = \text{Displacement}$$

Sizing example:

$$10,000\text{lbs/hr} \div 40\text{lbs/cuft} = 25\text{-cuft/hr}$$

It is best to select a size which will operate between 8RPM and 20RPM

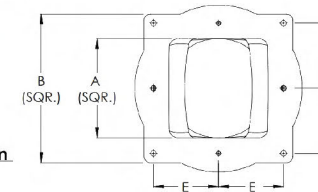

INLET FLANGE
(SQUARE DRILL PATTERN)

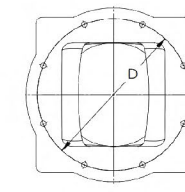

INLET FLANGE
(ROUND DRILL PATTERN)

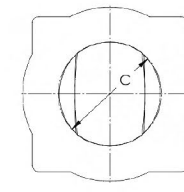

DISCHARGE FLANGE
(SAME DRILL PATTERN AS INLET FLANGE)

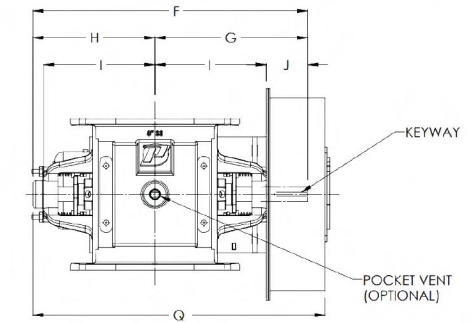
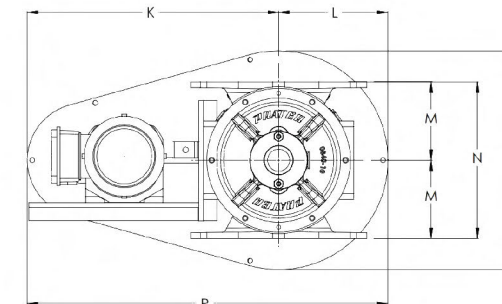

- Note:**
- Speeds 7RPM or less use a non-standard low output motor/reducer
 - Speeds 8RPM or greater use a standard output motor/reducer
 - Non-standard motor/reducers will result in an additional charge

Model	Displacement @ 100% Fill Efficiency (CU. FT/REV)	A	B	C	D	E	F	G	H	I	J	K	L	M	N	O	P	Q	HOLE (QTY)	KEYWAY W X D	DRIVE SHAFT DIA.	FLANGE THK.	WEIGHT (LBS)	W/ DRIVE (LBS)
PAV-6	.15	6	10	6	9 1/2	4 5/16	19 3/8	10 1/16	8 1/16	7 13/16	2 1/2	19 1/4	8 3/8	5	10	16 3/4	27 1/4	21 1/16	8	1/4 x 1/8	1	5/16	70	145
PAV-8	.30	8	12	8	11 3/4	5 1/4	21 15/16	12 1/4	9 5/16	8 13/16	3	19 1/4	8 3/8	6	12	16 3/4	27 1/4	23 1/16	8	1/4 x 1/8	1 3/16	7/16	110	215
PAV-10	.53	10	15	10	14 1/4	6	25 3/16	14 1/8	11 1/16	10 1/8	3 1/2	19 1/4	8 3/8	7 1/2	15	16 3/4	27 1/4	25 3/8	8	3/8 x 3/16	1 1/16	1/2	230	325
PAV-12	.95	12	18	12	17	7 3/4	29 15/16	16 11/16	13 3/4	12	3 3/8	27 29/32	9 5/16	9 1/16	18 1/8	19 1/8	37 15/32	30 7/16	8	3/8 x 3/16	1 3/4	5/8	420	560
PAV-14	1.475	14	19	14	18 3/4	4 1/4	15 21/32	21	2 7/16	16 11/16	14 1/4	35 1/16	10 1/2	10 1/8	20 1/4	32 3/8	38 3/8	34	12	1/2 x 1/4	1 15/16	5/8	620	765
PAV-16	2.30	16	22	16	21 1/2	5	15 13/16	23 1/2	2 7/16	17 25/32	15 3/4	36 13/32	11	11 1/16	22 7/8	33 21/32	39 7/8	39 7/32	12	1/2 x 1/4	1 15/16	3/4	720	840
PAV-18	2.75	17 15/16	24	N/A	N/A	5 1/4	39 3/4	21 3/16	18 5/16	17	4 1/4	28 1/8	12 1/2	13 1/2	27	19 5/16	40 5/16	41 5/16	16	5/8 x 5/16	2 3/8	7/8	2200	1900
PAV-22	4.32	22	27 5/16	N/A	N/A	5	46	25 1/4	20 2/3	19	6 1/4	35	15	15 1/2	31	23	50	47 3/4	20	3/4 x 7/16	3	1	1600	1400

Heavy Duty Series Rotary Airlock Valve

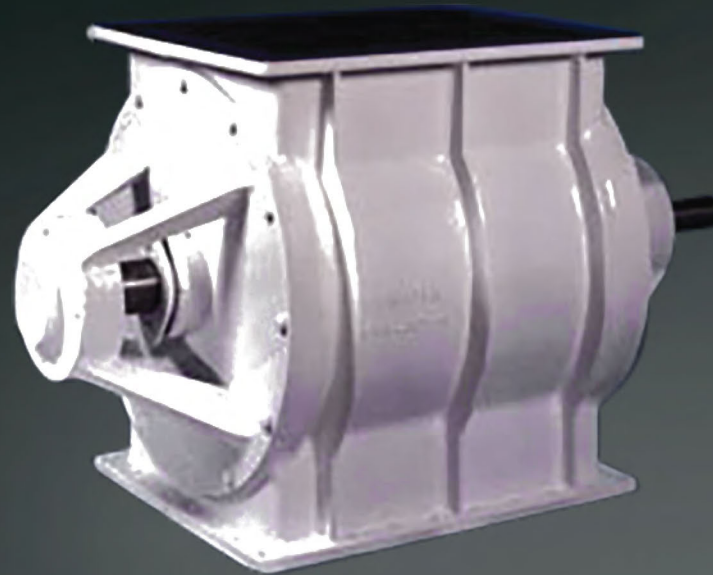

KEY BENEFITS

- Constructed of high strength cast iron or stainless steel body & end plates
- 8 blade, open-end rotor with welded pocket bottoms
- Self-adjusting, maintenance-free packing gland assemblies
- Outboard mounted, maintenance-free bearings
- Complimentary temperature compensation
- End plates pre-drilled & tapped for optional shaft air purge
- Quick and easy end plate removal using included jack bolt holes
- Operating temperature up to 500° F with standard components
- Keyed shaft extension for most drive assemblies
- Premium, inverter duty, helical gear motor
- Standard models in stock

OPTIONS

- Air purged seals
- Food grade Teflon seals
- Food grade white epoxy paint
- 304 or 316 stainless steel body & rotor
- Hastelloy body and rotor
- Shear pins / Zero speed switch
- High temp bearings & seals for operation to 1100° F
- Wear & corrosion resistant coatings
- Inlet baffle / Inlet v-plow for shear protection
- Discharge adapter / Finger guards
- Bolt on or flexible tips
- Vented pockets / Vented housing
- Die cut flange gaskets
- Manual hand crank or pneumatic maintenance gates available
- Drive: TEFC, or TEXP / Various voltages available

THE ONLY AIRLOCK
IN NORTH AMERICA TO BE
TESTED & CERTIFIED
TO COMPLY WITH NFPA-69



- NFPA-69
- MSHA
- V-Plow
- 10-Bar
- PSR11
- CSA

Rectangular (PAV Series)

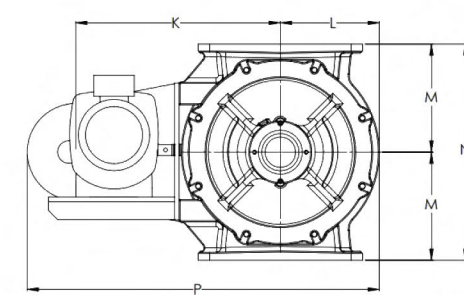
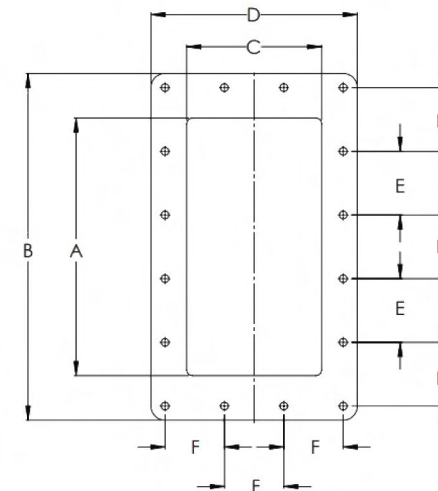
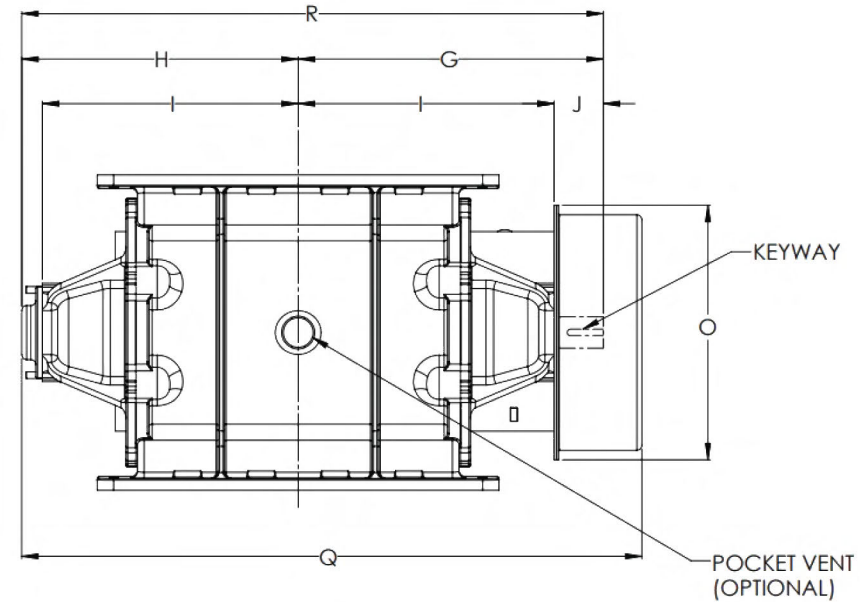

RPM

Airlock Capacity Table

Size	1420	1824	2830
CF/Rev	1.04	2.4	7.76
Displacement in cubic feet per hour (Calculated at 80% efficiency)			
3	187	432	1397
4	250	576	1862
5	312	720	2328
6	374	864	2794
7	437	1008	3259
8	499	1152	3725
9	562	1296	4190
10	* 624	1440	4656
11	686	1584	5122
12	749	1728	5587
13	811	1872	6053
14	874	2016	6518
15	* 936	2160	6984
16	998	2304	7450
17	1061	2448	7915
18	1123	2592	8381
19	1186	2736	8846
20	1248	2880	9312
21	1310	3024	9778
22	* 1373	3168	10243
23	1435	3312	10709
24	1498	3456	11174
25	1560	3600	11640
26	1622	3744	12106

- Note:**
- Speeds 7 RPM or less use a non-standard low output motor/reducer
 - Speeds 8 RPM or greater use a standard output motor/reducer
 - Non-standard motor/reducers will result in an additional charge

* Available in Direct Drive

Model	Displacement @ 100% Fill Efficiency (CU. FT/REV)	A	B	C	D	E	F	G	H	I	J	K	L	M	N	O	P	Q	R	Hole (QTY)	Keyway W x D	Drive Shaft Dia.	Flange THK.	Weight (LBS)	Weight W/ Drive (LBS)
1420	1.3	23	18 1/2	10	14 1/2	5 5/8	6 1/2	19 7/8	16 5/16	15 5/16	4 9/16	28 1/8	8 3/16	10	20	19 3/8	37 13/16	38 5/16	36 7/16	12	3/8 x 3/16	1 3/4	3/8	540	625
1824	3.0	30 5/8	22 3/4	12	18 1/4	5 5/8	5 1/4	23 1/4	21 1/8	19 1/2	3 3/4	28 1/8	9 5/16	12	24	19 3/8	39 1/8	47 1/4	44 5/16	16	5/8 x 5/16	2 3/8	1	1275	1400
2830	9.7	35 1/2	29 1/2	22 1/2	28 1/2	3 3/4	3 3/4	36 5/8	29 7/16	27 1/16	8 15/16	37 1/2	14 1/8	18 1/4	36 1/2	22 7/8	54 3/4	67 3/16	66 1/8	32	3/4 x 7/16	3	7/8	3450	3825

Quick Take Apart Series Rotary Airlock Valve

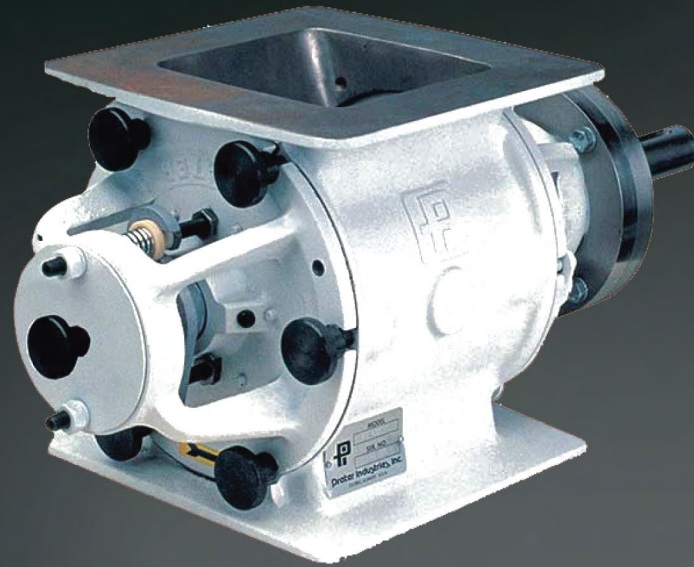

ABOUT

No tools are necessary for disassembly, cleaning and re-assembly of these airlocks.

Available in 6" and 8" sizes. These "QTA" Airlocks have all the standard features of the entire Prater line of Airlocks that includes the exclusive Self-Adjusting Packing Glands and the Round or Square pattern flanges. They are available in stainless steel and mild steel cast body with cast end plates.

- The Basic Valve Consists Of A Machined Cast Body And End Plates
- Square Inlet And Round Outlet- With Universal Flange
- Flanges Custom Drilled To Customer's Pattern
- End Plates Are Drilled And Tapped For Optional Air Purged Seals
- 8 Blade, Mild Steel, Open Ended Rotor With Welded Pocket Bottoms
- (2) Sealed Outboard Bearings - Lubricated For Life
- Jack Bolt Holes Are Drilled In End Plates For Quick And Easy Removal
- (2) Self Adjusting Packing Gland Assemblies

FEATURES AND BENEFITS

- Temperatures up to 500°F
- Up to +/- 12 PSI pressure differential
- Cast iron or stainless construction
- Direct drive gear-motors (9, 15, 23 RPM)
- Eight-blade rotors
- Tool-less removal of rotor
- Sizes 6 and 8 inch square

AVAILABLE OPTIONS

- Air Purge Seals
- Food Grade White Epoxy Paint
- Inlet Baffle
- Discharge Adapter
- Vented Pockets
- Neoprene Flange Gasket

Quick-Take-Apart (QTA Series)

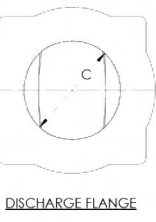
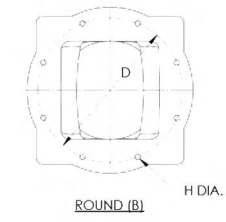
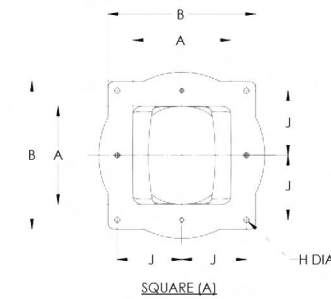
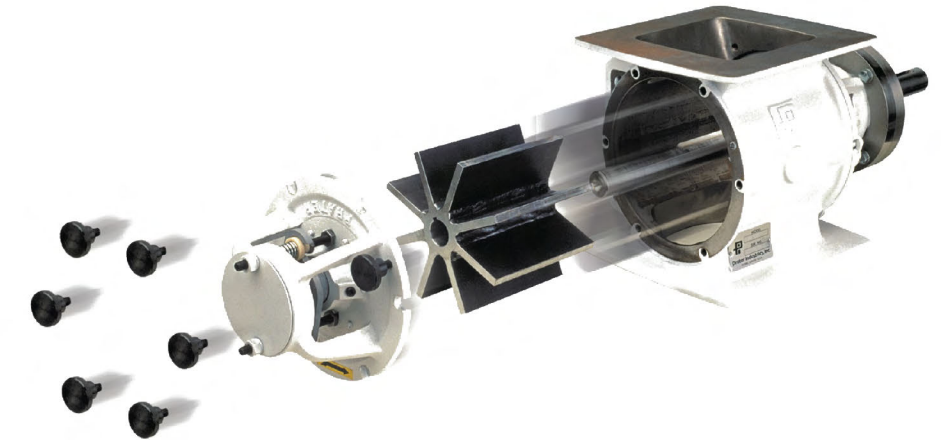
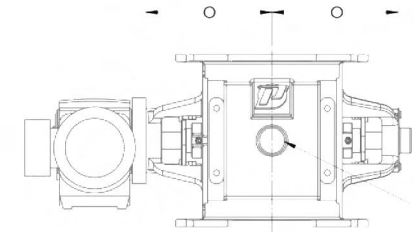
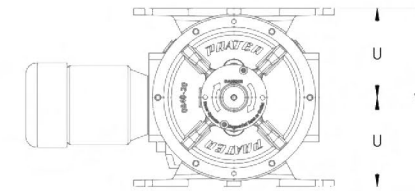
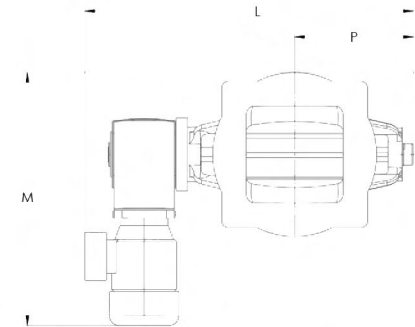

MODEL	A	B	C Dia.	D Dia.	H
QTA-6 C/S	6	10	6	9 1/2	7/16
QTA-8 C/S	8	12	8	11 3/4	7/16
MODEL	J	L	M	N	O
QTA-6 C/S	4 5/16	23 1/2	19 9/16	5	7 13/16
QTA-8 C/S	5 1/4	25 3/16	20 9/16	6	8 13/16
MODEL	P	S	U	V	Motor H/P
QTA-6 C/S	7 7/8	5 1/4	5	10	1/2
QTA-8 C/S	8 7/8	6 1/4	6	12	1/2

Quick Take Apart Series Rotary Airlock Valve

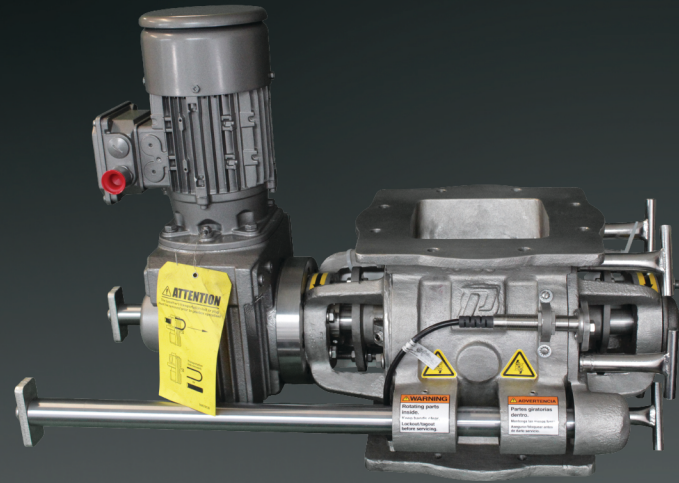

ABOUT

No tools are necessary for disassembly, cleaning and reassembly of these airlocks.

Available in 6", 8", 10" and 12" sizes. These "BAV" Airlocks have all the standard features of the entire Prater line of Airlocks that includes the exclusive Self-Adjusting Packing Glands and the Round or Square pattern flanges. They are available in stainless steel only.

- The Basic Valve consists of a Cast Stainless Steel Machined Body and End Plates
- Square Inlet And Round Outlet- With Universal Flange
- Flanges Custom Drilled To Customer's Pattern
- End Plates Are Drilled And Tapped For Optional Air Purged Seals
- 8 Blade, Stainless Steel, Open Ended Rotor With Welded Pocket Bottoms
- (2) Sealed Outboard Bearings - Lubricated For Life
- Jack Bolt Holes Are Drilled In End Plates For Quick And Easy Removal
- (2) Self Adjusting Packing Gland Assemblies

AVAILABLE OPTIONS

- Air Purge Seals
- Inlet Baffle
- Discharge Adapter
- Vented Pockets
- Neoprene Flange Gasket

FEATURES AND BENEFITS

- Tool-less access for immediate use and maintenance
- Self-centering rotor and rail design for quick reassembly to maximize uptime
- Rail design protects against dropping of the rotor in awkward locations
- Quick and easy disassembly for inspection and clearing of jams or plugging
- Available in sizes from 6 inch through 12 inch
- CNC machined components for precision clearances
- Direct drive design which allows for fewer moving parts and no pinch points
- Self-adjusting packing glands for continued packing pressure
- Standard eight vane beveled tip design which provides relief so the rotor can travel smoothly through material
- Rail design has 3X load capacity vs. competition

Quick-Take-Apart (QTA Series) On Rails

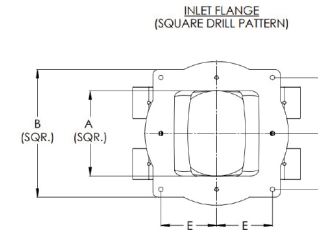
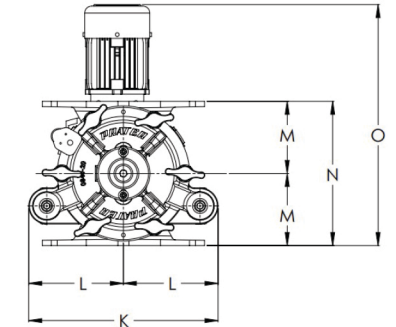
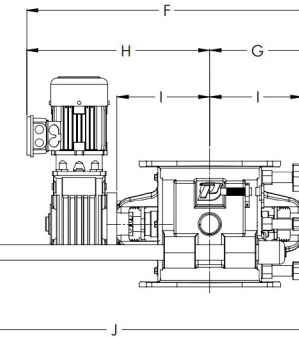
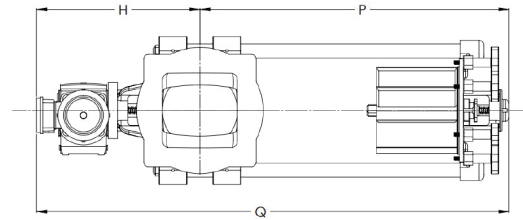

DISCHARGE FLANGE
(SAME DRILL PATTERN AS INLET FLANGE)

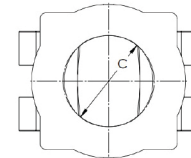

INLET FLANGE
(ROUND DRILL PATTERN)

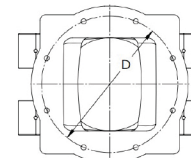

MODEL	A	B	C Dia.	D Dia.	E
BAV-6 C/S	6	10	6	9 1/2	4 5/16
BAV-8 C/S	8	12	8	11 3/4	5 1/4
BAV-10 C/S	10	15	10	14 1/4	6
BAV-12 C/S	12	18	12	17	5 1/8, 5 1/4, 5 1/8

MODEL	F	G	H	I	J
BAV-6 C/S	25 1/2	8 7/8	16 5/8	7 13/16	28 15/16
BAV-8 C/S	27 1/8	9 13/16	17 5/16	8 13/16	37 3/4
BAV-10 C/S	29 15/16	11 1/4	18 11/16	10 1/8	42 3/16
BAV-12 C/S	32 15/16	12 3/8	20 9/16	12	45 9/16

MODEL	K	L	M	N	O
BAV-6 C/S	13 5/8	6 13/16	5	10	19 1/16
BAV-8 C/S	15 3/4	7 7/8	6	12	20 1/16
BAV-10 C/S	19 15/16	9 31/32	7 1/2	15	23 31/32
BAV-12 C/S	22 1/2	11 1/4	9 1/16	18 1/8	29 1/8

MODEL	P	Q	R Bolt Hole Dia.	Motor H/P
BAV-6 C/S	25	41 5/8	7/16	1/2
BAV-8 C/S	33	50 5/16	7/16	3/4
BAV-10 C/S	36 9/16	55 1/4	7/16	1
BAV-12 C/S	38 3/8	55 15/16	7/16	1 1/2

Blow-Thru Rotary Airlock Valve



ABOUT

The Prater Blow-Thru Rotary Airlock Valves are designed and manufactured specifically for applications that require discharging into a pneumatic conveying line. These Airlocks are ideal for free flowing materials that require some assistance in clearing the rotor vane pockets.

The design of the Prater Blow-Thru Airlock makes installation possible in low headroom applications and retrofits of existing rotary valves. Also, like all Prater Rotary Airlock Valves, the blow through design features an innovative, larger vane pocket design. The larger rotary vane pockets allow up to 50% more volume which enables the rotor to run at lower speeds than other manufacturers' rotary airlock and valve feeders which increases efficiency and equipment life. These features provide you with a blow through rotary airlock valve that has minimum air leakage, a longer life, less maintenance and a higher return on investment.

AVAILABLE FEATURES

- Cast Iron or Stainless Steel Construction
- (2) Sealed outboard bearings - lubricated for life
- (2) Prater exclusive, Self-adjusting packing gland assemblies
- Eight-blade rotors standard (choice of speed)
- Sizes 8 and 10 inches
- Up to +/- 12 PSI pressure differential

**THE ONLY AIRLOCK
IN NORTH AMERICA TO BE
TESTED & CERTIFIED
TO COMPLY WITH NFPA-69**



Blow-Thru (PBT Series)

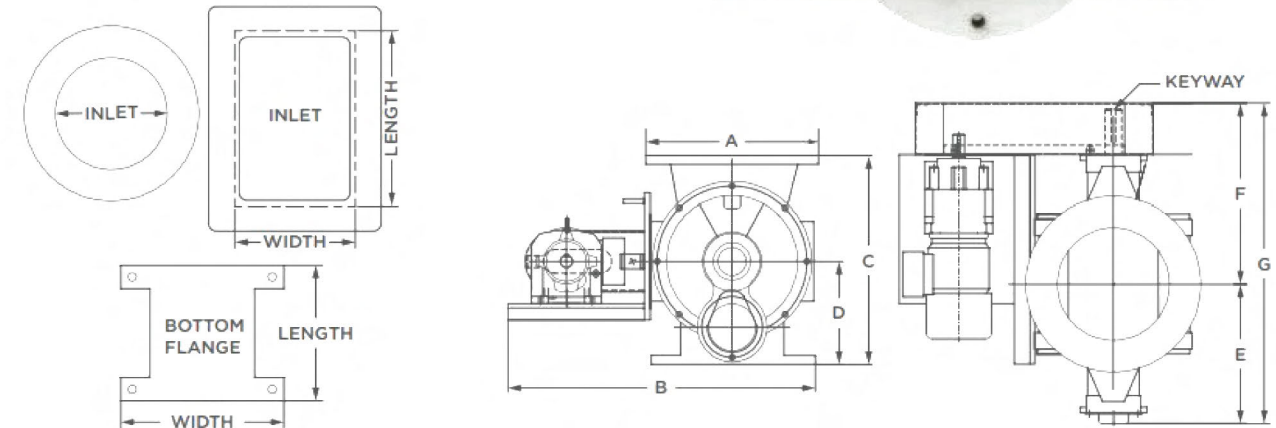

Model	Displacement @ 100% Fill Efficiency (CU. FT/REV)	Top Flange	Bottom Flange	Flange THK.	Inlet	A	B	C	D	E	F	G	Keyway W x D	Shaft Drive DIA.	Weight (LBS)	Approx. Weight W/Drive (LBS)
PBT-8	0.33	13 3/8 DIA.	12 18/32 W x 9 7/16 L	25/32	7 7/8 DIA.	13 3/8	25 27/32	15 9/16	17 21/32	10 18/32	12 21/32	23 9/32	1/4 x 1/8	1 3/16	160	260
PBT-10	0.61	15 1/22 DIA.	13 29/32 W x 11 13/22 L	25/32	9 27/32 DIA.	15 11/32	25 29/32	17 17/32	8 25/32	12 3/16	15 13/16	28	3/8 x 3/16	1 7/16	275	340

Dust Collector Series Rotary Airlock Valve



KEY BENEFITS

- Configuration available for quick shipment
- Low height - easy retrofit into competitive airlock spaces
- Temperatures up to 300° F
- Up to +/- 3 PSI pressure differential
- Custom drilled flanges for customer's pattern at no charge

FEATURES

- Ultra close rotor/housing clearances for best seal
- Cast iron construction
- Heavy cast housing & end plates for maximum rigidity
- Maintenance-free inboard bearings
- Direct drive gear-motors (29 RPM)
- Sizes: 6, 8, 10 and 12 inch square
- Eight-blade rotors standard

OPTIONS

- Beveled Rotor Tips - Increases operating efficiency by minimizing drag and horse power
- Motion Switch - A non-contact sensor that indicates loss of speed or zero speed, preventing damage to system components
- TEXP Motor - For use in hazardous environments
- Flexible Rotor Tips - For handling stringy or fibrous products that cause conventional rotors to jam



The DCS series is available in sizes 6, 8, 10, and 12. Refer to page 6 for capacity and dimensional data as they are the same as those sizes in the Prater Square (PAV) series.

Abrasion Resistant Rotary Airlock Valve

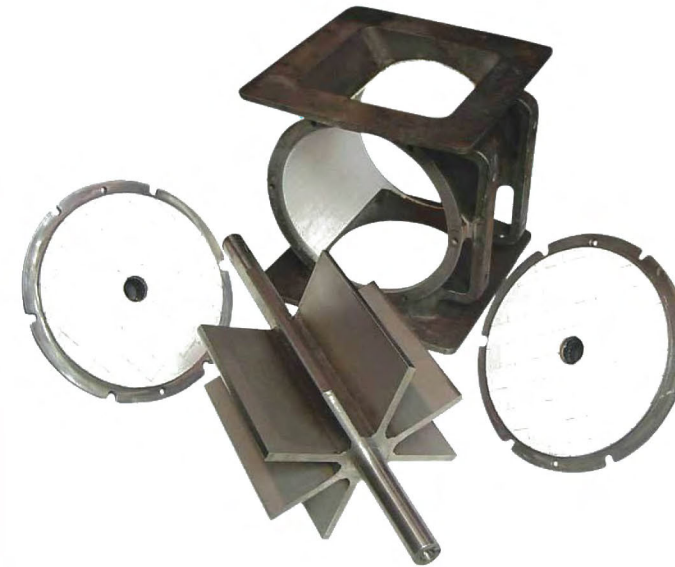

WHEN HEAVY-DUTY JUST ISN'T ENOUGH

Prater has your solution to airlocks that constantly wear out in high abrasive applications. For over 45 years, Prater Industries has manufactured thousands of airlocks for almost every free flowing dry material application. Prater Airlocks are selected to feed material from a bin or hopper, to deliver fines from a collector while sealing against air loss and to feed material into a pneumatic conveying system against pressure or vacuum.

Prater's special treatment process allows Prater Abrasion Resistant Rotary Airlock Valves to withstand even the most abrasive applications, achieving better performance than airlocks made of cast iron or stainless steel. With less down-time, Prater Abrasion Resistant Rotary Airlock Valves reduce maintenance costs and help avoid losses in production, all the while achieving higher efficiency by holding our tighter tolerances longer.

Our Abrasion Resistant Rotary Airlock Valves boast a heavy cast housing with oversized mounting flange, heavy-duty outboard bearings, self-adjusting packing glands (a Prater Exclusive), and predrilled end plates for air purge. Abrasion Resistant Rotary Airlock Valves options include, ceramic lined end plates, ceramic lined housings, and tungsten carbide throat.

FEATURES

- Cast-iron housing & end plates with abrasion resistant lining
- 8-blade rotor
- Universal flanges that match most existing bolt hole patterns
- 2 outboard bearings

THE ONLY AIRLOCK
IN NORTH AMERICA TO BE
TESTED & CERTIFIED
TO COMPLY WITH NFPA-69 

SIGNIFICANTLY IMPROVES PERFORMANCE WITH:

- Aluminas
- Cement
- Clay
- Coke
- Carbon Black
- Coal
- Gypsum
- Limestone
- Fly Ash
- Pot Ash
- PVC Pellets
- Silica
- Stucco
- TiO2

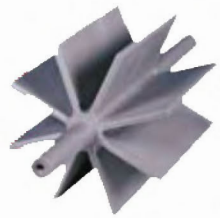

BEVELED ROTOR BLADES:

Used with fine products that can smear or pack between the housing and rotor tips. The trailing edge of each blade is machined at a 15° angle, narrowing the “land area.” This feature increases operating efficiency by minimizing drag and horsepower.



CLOSED END ROTORS:

Built with side plates machined to the same diameter as the blade tips, sealing the entire pocket at the rotor diameter. These rotors reduce wear on the end plates and shaft seals, reduce air leakage and contain certain types of free-flowing products that tend to “flush through.”



SHALLOW POCKET ROTORS:

Rotors designed to reduce displacement by 25%, 50% or 75% of the original capacity. They are used for two purposes: 1) to handle sticky products that tend to pack in the narrow pocket bottoms and 2) when a higher RPM is required to provide accurate, continuous flow in feeding applications.



REMOVABLE WEAR BARS:

Wear bars offer an effective means of renewing the wear portion of the rotor. Prater offers two types of wear bars: L-Slot (A Prater Exclusive) for use when a precise air-seal is required and Bolt-On for general use. Various materials, such as brass, Neoprene, Teflon, stainless steel and certain alloys are available.

INLET BAFFLES:

Used when handling larger particles or pellets that can shear or jam between the rotor tips and housing. Inlet baffles limit material to filling the back half of the pocket, wipe the blade tips prior to entering the housing and reduce degradation of friable materials.

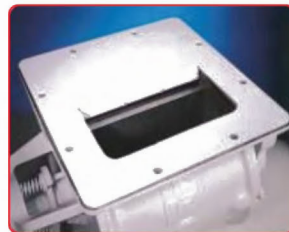

DROP THROUGH ADAPTORS:

Efficiently designed to transition the airlock discharge to a pneumatic conveying line while adding minimal height to the valve. Compared to “blow through” airlocks, where pneumatic air forces material through the rotor pocket, drop-through designs result in minimal wear of the valve internals.



V-PLOW:

Either cast or fabricated depending upon the model and size, the V-plow will often times be specified for wood or pellet applications. The V-Plow can extend the rotor and housing life and eliminate jamming.



Prater’s Customer Service and Support Team stands ready to support you. Simply contact us by calling our Parts and Service Department at (855) 957-4608 and a customer care specialist will be in touch.

At Prater, we encourage customers to consult with our experienced, professional Customer Service Representatives with any and all equipment support inquiries. They are all available to assist with the following services:

- Parts Inquiries/Quotes
- Technical Support
- Product Manuals
- Parts Orders
- Warranty Information
- Equipment Rebuilds
- Technical Documentation
- Spare Parts Lists
- Ordering Replacement Parts
- Shipping Inquiries
- Field Service and Repair
- Parts Order History
- PM Agreements
- Returns

ROTARY AIRLOCK VALVE PARTS



PREVENTATIVE MAINTENANCE PROGRAM

Prater Industries is pleased to offer Preventative Maintenance Services to our valued customers. Customers who perform routine factory inspection/maintenance of their equipment, experience less downtime, reduced annual parts costs and optimize efficiency of their systems.



WHY A CUSTOMER SHOULD KEEP A SPARE PARTS INVENTORY

- Minimize downtime and keep essential equipment running without interruption
- Parts may be out of stock at the factory
- Lead time on non-stock parts can be too long for your application
- Critical spares - if you have a need for a spare part that is critical to your operations and the predominant failure mode is unpredictable, catastrophic failure, then your planning horizon is effectively zero and so you should definitely hold a spare part.
- A spare parts inventory should consist of any items that could cause extended downtime if a failure occurs